

B.O.M. for PTK-20			
ITEM	QTY.	PART NO.	DESCRIPTION
(3)	1	802301-1629000	16 GAUGE WIRE - BLUE
(4)	1	802301-16910000	16 GAUGE WIRE - BROWN
(5)	2	802304	3M #902 - IDC WIRE TAP 12 TO 18 AWG
(8)	1	802411-02	PHOENIX CONNECTOR - 2 POLE #1911965
(9)	2	802414-06	PANDUIT INSLD. FERRULE - 16AWG #FSD78-8-D
(11)	A/R	802420-01	HEAT SHRINK, WHITE PRINTABLE - DETAIL A

() = SEE CHART FOR QUANTITY A/R = AS REQ'D

ASSEMBLY NOTES:

1. AFTER HARNESS IS WIRED, USE ITEM #10 TO TIE WRAP ITEMS #1 AND #2 TOGETHER EVENLY SPACED ALONG THE LENGTH OF CABLE ASSEMBLY.
2. MARK DESIGNATED TEXT AT APPROXIMATE POSITION SHOWN IN BLACK UPPER CASE GOTHIC STYLE CHARACTERS. CHARACTERS SHALL BE CLEARLY LEGIBLE AND SHARPLY DEFINED. MARKING MATERIAL SHALL BE PERMANENT, NON-NUTRIENT AND NON-CONDUCTIVE.
3. PLACE LABEL APPROXIMATELY 1" FROM TERMINATION POINT TO BEGINNING OF LABEL EDGE.
4. IN DETAIL A REPLACE "#" WITH THE APPROPRIATE PART NO. SUFFIX AS SHOWN ON THE CHART TO THE RIGHT DETERMINED BY COLUMN "A"; EXAMPLE GIVEN "1" FOR A=25, "2" FOR A=49, ETC.
5. LABEL MUST BE A HEAT SHRINKABLE WIRE MARKER SLEEVE. HAND WRITTEN OR WRAP AROUND TYPE LABELS ARE NOT ACCEPTABLE.
6. FOLLOW MANUFACTURERS INSTRUCTIONS FOR WIRE STRIP LENGTH AND RECOMMENDED TIGHTENING TORQUE ON ALL SCREW TERMINATIONS.
7. SHOWN FOR REFERENCE PURPOSES ONLY.

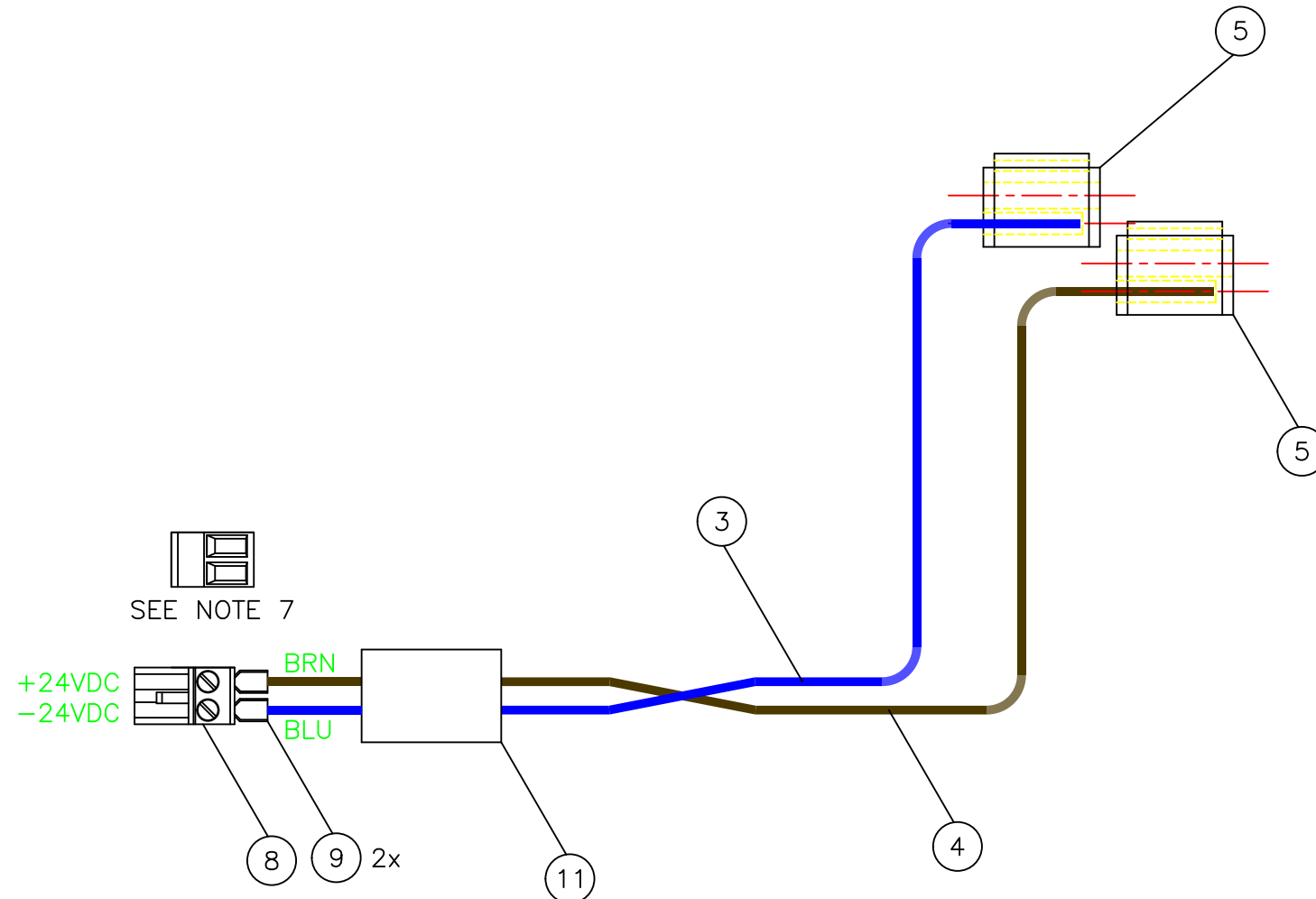

REV.	DATE	DESCRIPTION	✓	<p>THE INFORMATION CONTAINED HEREIN IS CONFIDENTIAL, IS SUBMITTED IN CONFIDENCE AND IS PROPRIETARY INFORMATION OF INSIGHT AUTOMATION INC. AND SHALL BE USED ONLY IN CONJUNCTION WITH, AND PERFORMANCE OF, THE CONTRACT OF WHICH THIS DRAWING FORMS A PART, AND SHALL NOT, WITHOUT INSIGHT AUTOMATION, INC. PRIOR WRITTEN APPROVAL, BE REPRODUCED OR IN ANY OTHER WAY USED IN WHOLE OR IN PART BY OTHERS.</p>	<p>DATE: 03/21/2014</p> <p>DESIGNED BY:</p> <p>CHECKED BY:</p>	<p>CUST.NO:</p> <p>EST.NO:</p> <p>ORD.NO:</p> <p>SCALE: NONE</p> <p>SHEET: 1</p>	<p>TITLE: POWER DISTRIBUTION HARNESS POWER TAP KIT</p> <p>FOR: CONTROL DRAWING</p> <p>DWG. NO: PTK-30</p> <p>REV:</p>
------	------	-------------	---	--	--	--	---

